

FRESHBOX 100



Single-room heat recovery unit

Air capacity up to 100 m³/h
Heat recovery efficiency up to 96 %

CONTENTS

FRESHBOX 100 FEATURES	3
DESIGN	4
OPERATING PRINCIPLE	6
CONTROL	6
APPLICATION OPTIONS	7
TECHNICAL DATA	8
OVERALL DIMENSIONS	8
ACCESSORIES	9

FRESHBOX 100 is a single-room energy-efficient supply and exhaust unit intended for decentralised ventilation of social and commercial spaces as well as apartments and houses.



The best solution for creating simple yet highly efficient ventilation systems in newly erected and renovated spaces without requiring ducting installation.



FEATURES

- Efficient solution for supply and exhaust ventilation of enclosed spaces.
- Electric preheating or post-heating is available for cold climate conditions.
- Modification with a heat exchanger equipped with an enthalpy core is available for humid and hot climate conditions.
- Low-energy EC fans.
- Silent operation (25-38 dB(A)).
- Supply air purification ensured by two built-in G4 and F8 filters (optionally H13).
- Upgradeable with an exhaust duct to provide air extraction from the bathroom.
- Easy installation.
- Compact size.

DESIGN

Casing

Polymer coated metal casing decorated with an acrylic front panel. Heat and noise insulation is ensured by a layer of 10 mm cellular synthetic rubber.

The front panel provides convenient access for filter maintenance and has a lock for extra security.

The unit has two Ø100 mm pipes for fresh air intake and stale air extraction outside. The third Ø100 mm pipe (included in the scope of delivery) can be additionally fitted to the unit to connect the exhaust air duct from the bathroom.

Motors

The units feature efficient electronically commutated (EC) motors with an external rotor and impellers with forward curved blades. These state-of-the-art motors are the most advanced solution in energy efficiency today.

EC motors are characterised with high performance and optimum control across the entire speed range. In addition to that the efficiency of electronically commutated motors reaches very impressive levels of up to 90 %.

Air dampers

The unit is equipped with supply and exhaust air dampers which activate automatically to prevent drafts while the unit is off.

EH Freshbox 100 heater for condensate freeze protection (optional)

Operation in a cold climate may result in condensate freezing in the exhaust air duct and the external hood. Therefore, it is recommended to install the **EH Freshbox 100** heater (purchased separately) to prevent icing.

Air filtration

Supply air cleaning is provided by the **G4** and **F8** panel filters (PM2.5 > 75 %). To meet more stringent air purity requirements the F8 filter can be replaced with an H13 (PM2.5 > 95 %) (purchased separately). Exhaust air is cleaned by the panel filter G4.

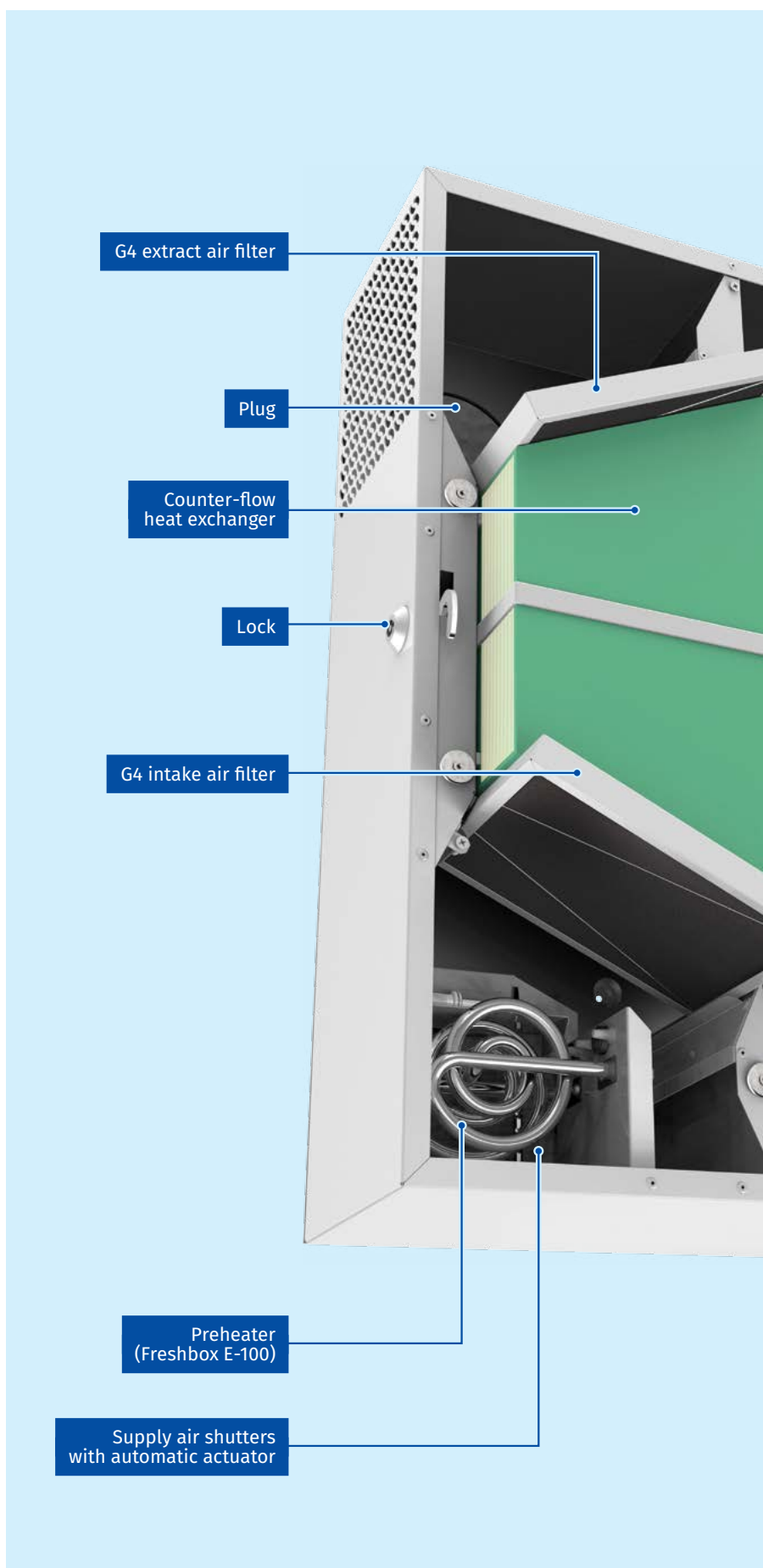
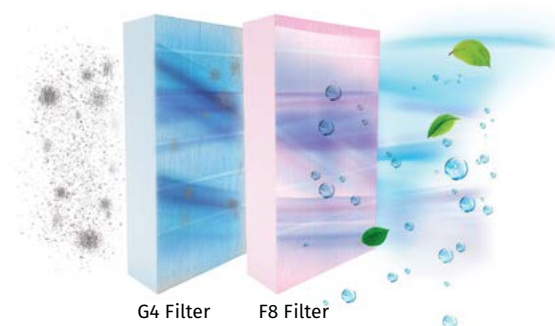

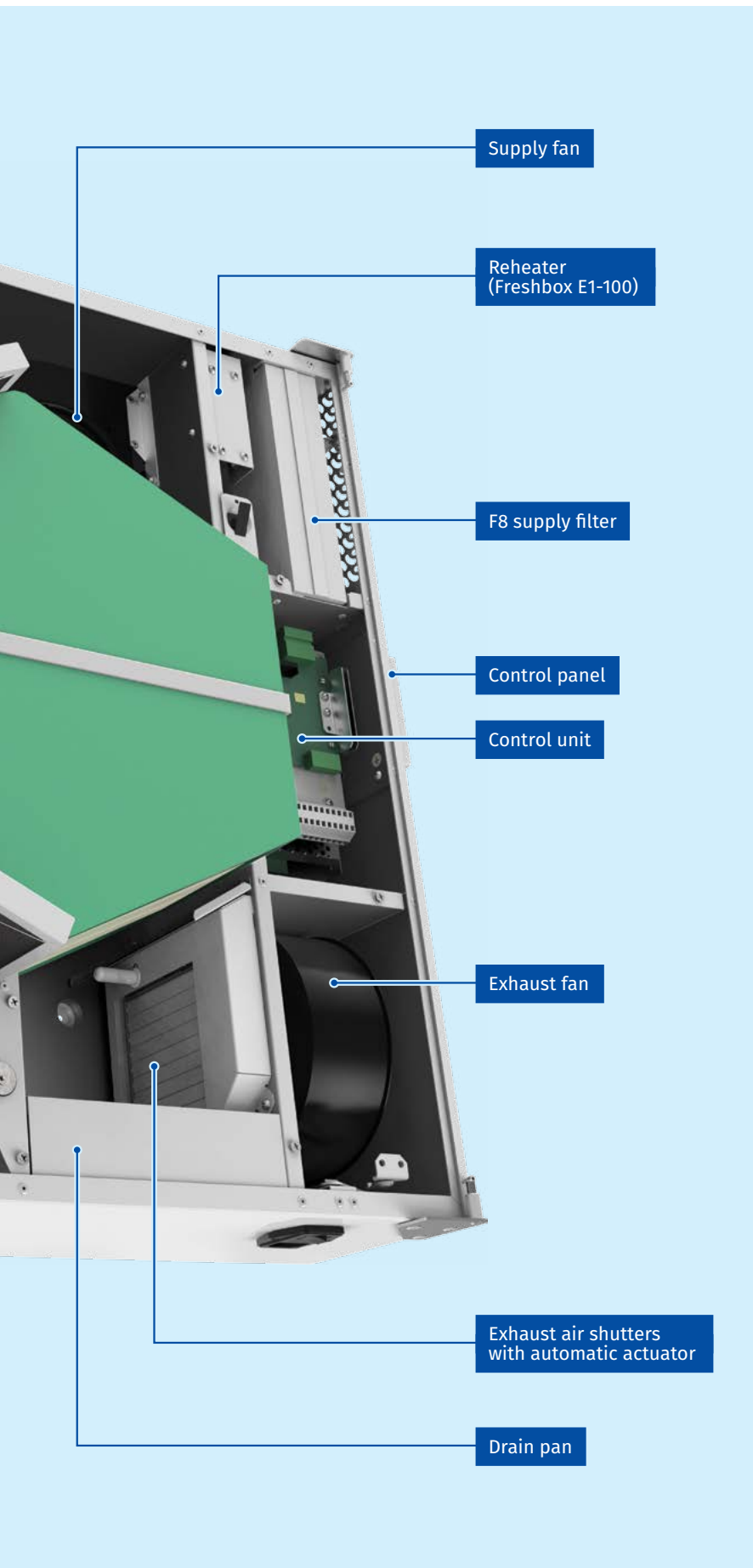

Preheating

Freshbox E-100 units are equipped with an electric preheater which protects the heat exchanger from freezing.

Post-heating

Freshbox E1-100 units feature an electric post-heater to raise the supply air temperature as necessary.

Heat exchanger

The **Freshbox 100** units are equipped with a counter-flow heat exchanger with a polystyrene core.

In the cold season the exhaust air heat is captured and transferred to the supply air stream which reduces the ventilation-generated heat losses.

Some condensate may form during heat recovery. The condensate is collected in the drain pan and is removed from the exhaust air duct.

In the warm season the intake air heat is transferred to the extract air stream. This allows for a considerable reduction of the supply air temperature which, in turn, reduces the air conditioning load.



The **Freshbox 100 ERV** units are equipped with a counter-flow heat exchanger with an enthalpy membrane at the core.

In the cold season the exhaust air heat and moisture are transferred to the supply air stream through the enthalpy membrane reducing the heat losses through ventilation.

Consequently, it is the intake air heat and moisture transferred to the extract air stream through the enthalpy membrane **in the warm season**. This allows for a considerable reduction of the supply air temperature and humidity which, in turn, reduces the air conditioning load.



OPERATING PRINCIPLE

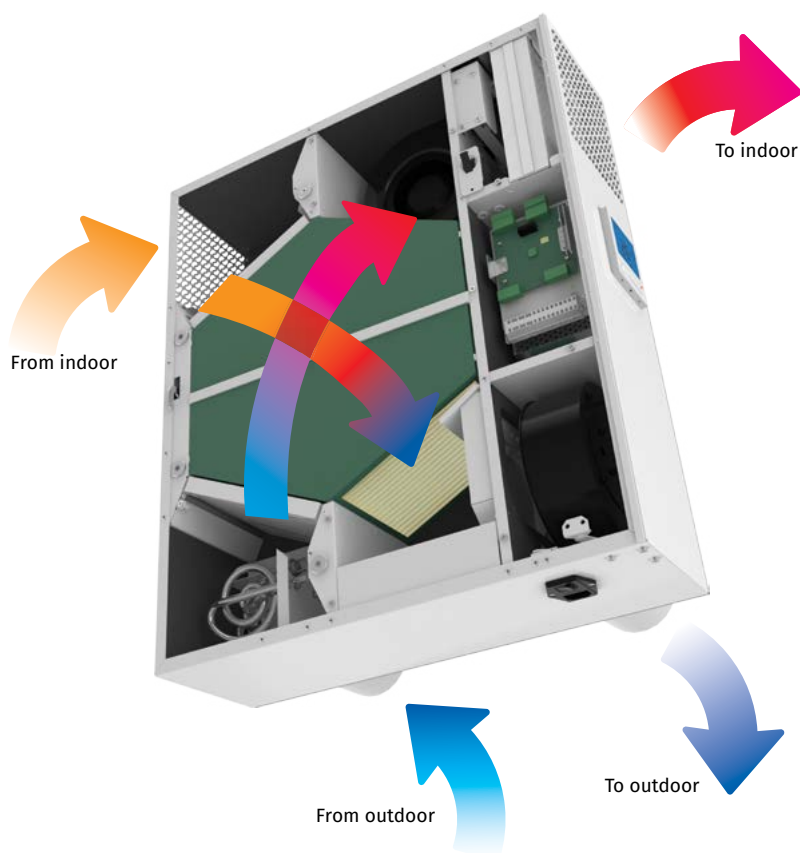

The **cold outdoor air** passes through the filters and the heat exchanger and then is delivered to the serviced space by the supply centrifugal fan.

Warm stale air from indoors passes through the filter and the heat exchanger and is discharged outdoors by the centrifugal fan.

The **supply and exhaust air** flows are fully separated which helps eliminate the possibility of odour or microbial transfer between the streams.

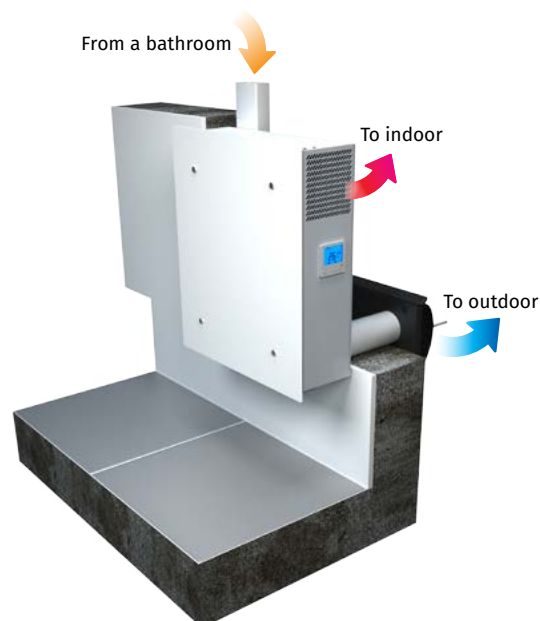

Operating principle with extra spigot for bathroom exhaust ventilation

CONTROL



The unit is equipped with a control panel.
The remote control is supplied as standard.

Functions

	Freshbox 100 Freshbox E-100	Freshbox E1-100
Speed changeover	•	•
Filter replacement indication	•	•
Alarm indication	•	•
Speed setting	•	•
Timer	•	•
Weekly schedule	•	•
Post-heating enabled/disabled		•
Supply air temperature setup		•

Freeze protection

There are two types of freeze protection available to protect the heat exchangers in the cold season.

Freshbox 100 features an exhaust air temperature sensor downstream of the heat exchanger which disables the supply fan to let the warm extract air warm up the heat exchanger. After that the supply fan is turned on and the unit reverts to the normal operation mode.

The **Freshbox E-100** units are equipped with an electric preheater which warms up the supply air upstream of the heat exchanger to prevent its freezing.

These features ensure a continuous balanced air exchange regardless of ambient air temperature variations.

APPLICATION OPTIONS

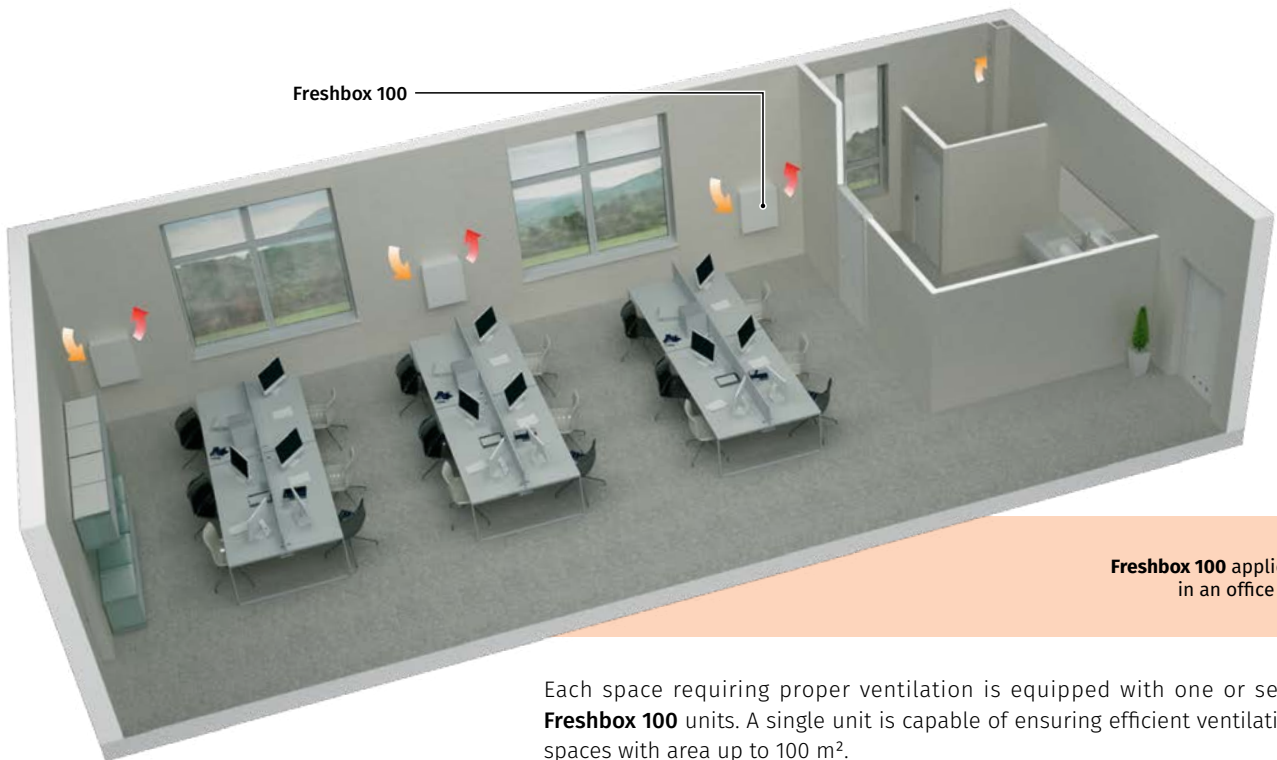

Freshbox 100 application in an office space

Each space requiring proper ventilation is equipped with one or several **Freshbox 100** units. A single unit is capable of ensuring efficient ventilation in spaces with area up to 100 m².

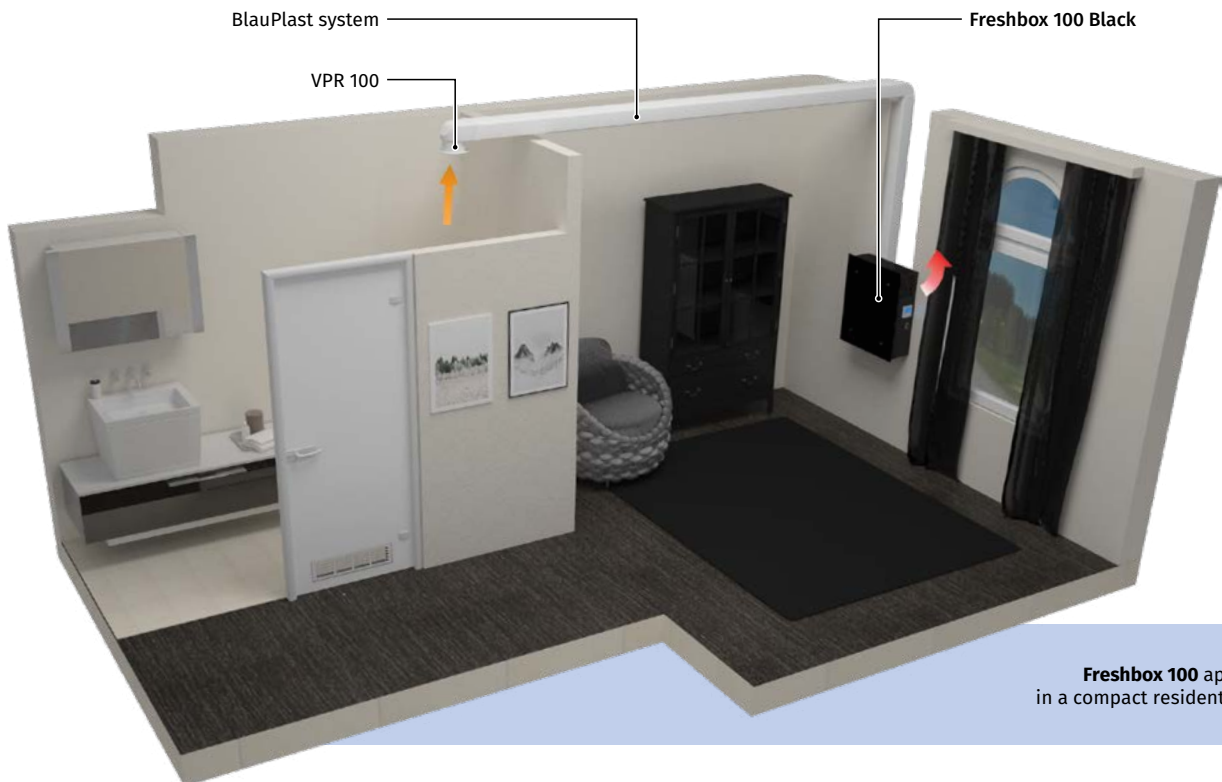

Freshbox 100 application in a compact residential space

The **Freshbox 100** units can be upgraded with a bathroom exhaust air duct. To enable such a configuration the units can be additionally equipped with an optional \varnothing 100 mm spigot (supplied as standard).

TECHNICAL DATA

Parameters	Freshbox 100			Freshbox 100 ERV			Freshbox E-100			Freshbox E-100 ERV			Freshbox E1-100			Freshbox E1-100 ERV		
	1	2	3	1	2	3	1	2	3	1	2	3	1	2	3	1	2	3
Speed	1-230																	
Unit voltage [V /50-60 Hz]	1-230																	
Max. unit power without an electric heater [W]	12	21	45	12	21	45	12	21	45	12	21	45	12	21	45	12	21	45
Preheating power [W]	-			-			600			600			-			-		
Post-heating power [W]	-			-			-			-			350			350		
Max. current consumption w/o electric heater [A]	0,35			0,35			0,35			0,35			0,35			0,35		
Max. current consumption with an electric heater [A]	-			-			3,08			3,08			1,94			1,94		
Maximum air capacity [m³/h]	30	60	100	30	60	100	30	60	100	30	60	100	30	60	100	30	60	100
RPM [min ⁻¹]	max 2200																	
Noise level @ 3 m [dB(A)]	13	27	39	13	27	39	13	27	39	13	27	39	13	27	39	13	27	39
Max. transported air temperature [°C]	from -25 up to +50																	
Casing material	polymer coated steel																	
Insulation thickness [mm]	10																	
Extract air filter	G4																	
Intake filter	G4 + F8 (Option: F8 Carbon; H13)																	
Connected air duct diameter [mm]	100																	
Weight [kg]	31																	
Heat recovery efficiency [%]	96	92	87	90	86	80	96	92	87	90	86	80	96	92	87	90	86	80
Heat exchanger type	counter-flow																	
Heat exchanger material	polystyrene			enthalpic membrane			polystyrene			enthalpic membrane			polystyrene			enthalpic membrane		
Energy efficiency class	A																	

*Heat recovery efficiency is specified in compliance with EN 13141-8.



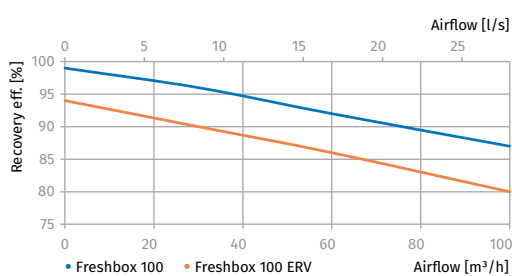
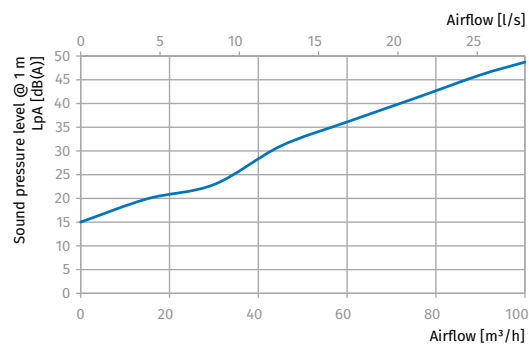
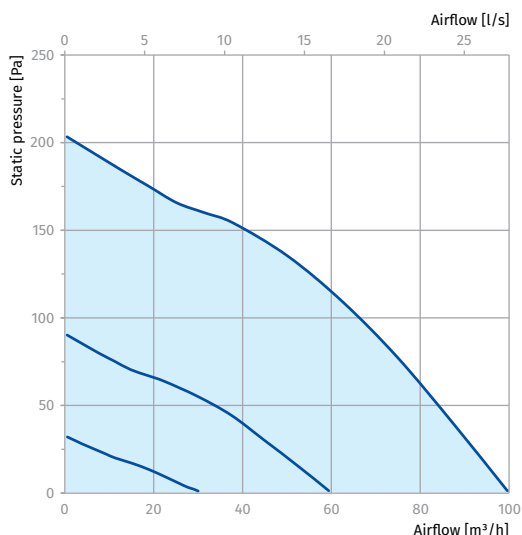



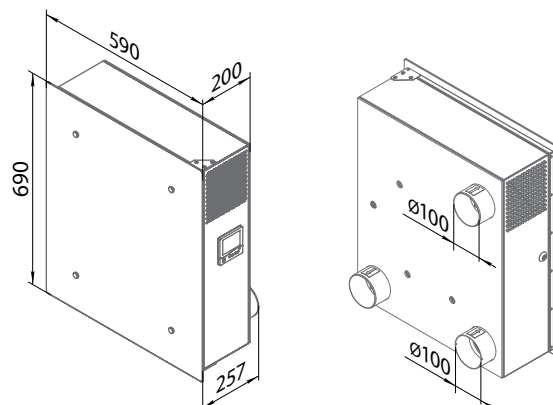





Sound power level, A-filter applied										Sound pressure level at 3 m., A-filter applied	Sound pressure level at 1 m., A-filter applied
Sound-power level, A-weighted	General	Octave frequency band [Hz]									
		63	125	250	500	1000	2000	4000	8000		
LwA to environment [dB(A)]	49	45	40	44	38	33	29	27	22	28	38



OVERALL DIMENSIONS [MM]



ACCESSORIES

Name	Image	Description
MS Freshbox 100 chrome		Mounting kit: <ul style="list-style-type: none"> • Two Ø 100 mm air ducts, 500 mm long • Ventilation outer hood made of polished steel • Cardboard template
MS Freshbox 100 white		Mounting kit: <ul style="list-style-type: none"> • Two Ø 100 mm air ducts, 500 mm long • Ventilation outer hood, painted white • Cardboard template
AH Freshbox 100 chrome		Ventilation outer hood made of polished steel.
AH Freshbox 100 white		Ventilation outer hood, painted white
EH Freshbox 100		Heater to prevent condensate freezing in the drain pipe and outer ventilation hood
FP 193x158x18 G4 PPI		G4 Filter
FP 193x158x47 F8		F8 Filter
FP 193x158x47 F8 C		F8 Carbon Filter
FP 193x158x47 H13		H13 Hepa Filter
HR-S		Humidity sensor
CD-1		CO ₂ Sensor with LED lights for indication of CO ₂ concentration and a touch button for operation mode switching
CD-2		CO ₂ Sensor

Blauberg Ventilatoren GmbH
Aidenbachstr. 52
D-81379 Munich

info@blaubergventilatoren.de
www.blaubergventilatoren.de

Technical changes reserved.
Illustrations and texts are non-binding.

03/2017